



EV4339-21

# Clariss Single Head

Filter head with 3/8" BSP fittings exclusively for Clariss replacement cartridges



Clariss Single Head: EV4339-21

## BENEFITS

Commercial quality filter head is designed exclusively to fit Clariss filter cartridges

Solid durable construction is ideal for foodservice and vending applications

Engineered for durability, strength and longevity

Will not corrode

## HEAD FEATURES

- Built-in flush port
- Auto shut-off
- Adjustable by-pass
- Flow restrictor
- Backflow restrictor

## INSTALLATION TIPS

The system can be operated freestanding, lying horizontally or mounted vertically

If mounting vertically to a wall, securely connect the mounting bracket to the wall using suitable screws

Water pressure at the filter system inlet must not exceed 116 psi (8 bar). A pressure reducer valve must be installed on the water supply side of the filter system if the inlet pressure exceeds 116 psi (8 bar)

Shut off valve must be installed upstream of the filter

Refer to Installation, Operation & Maintenance Manual for cartridge flushing and RO start-up

## OPERATION TIPS

Change Clariss cartridge when its pre-calculated water volume has been reached or at least once a year

Change cartridges when capacity is reached

Always flush the filter cartridge at time of installation and cartridge change

Do not use hardness test strips to check for hardness reduction, please use Titration kit to check for hardness reduction

## APPLICATION/SIZING

The CLARISS filter systems are typically used to feed the following appliances:

- Coffee and Espresso Machines
- Hot drink vending machines
- Combi steamers and self-cooking systems
- Steam cookers and ovens
- Brewed Iced Tea

The systems can be operated horizontally or vertically, depending on the space available

# Claris Single Head

## SPECIFICATIONS

### Dimensions:

5.78"H x 3.31"W x 4.68"D

No electrical connection required

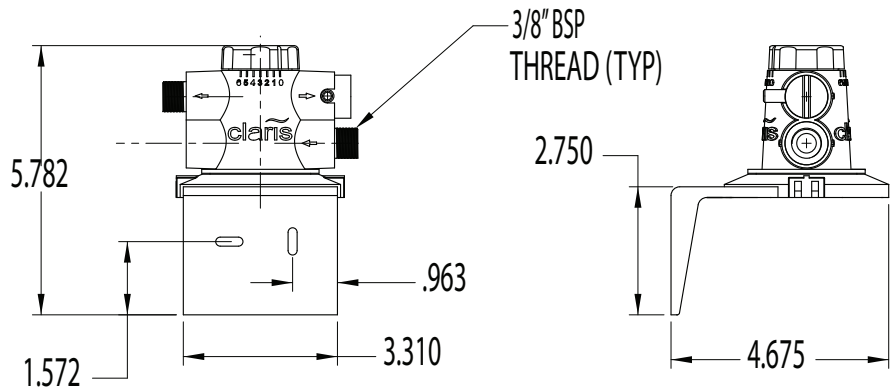

## WARRANTY

Everpure Claris water treatment systems are covered by a limited warranty against defects in material and workmanship for a period of one year after date of purchase. Everpure replaceable elements (filter cartridges and water are covered by a limited warranty against defects treatment cartridges) in material and workmanship for a period of one year after date of purchase. See printed warranty for details. Everpure will provide a copy of the warranty upon request.

### EVERPURE®

EVERPURE, LLC  
1040 Muirfield Drive  
Hanover Park, IL 60133  
Toll Free (800) 323-7873  
Tel. (630) 307-3000  
Fax (630) 307-3030  
www.everpure.com

In Europe:  
PENTAIR WATER BELGIUM bvba  
Industriepark Wolfstee  
Toekomstlaan 30  
B-2200 Herentals  
Belgium  
Tel. 32-14-283-500  
Fax 32-14-283-505

In Japan:  
EVERPURE JAPAN, INC.  
Hashimoto MN Bldg. 7F  
3-25-1 Hashimoto Sagamihara-Shi  
Kanagawa 229-1103  
Japan  
Tel. 81-(0)42-775-3011  
Fax 81-(0)42-775-3015